

TYPE C PLUG OVER MOLDING

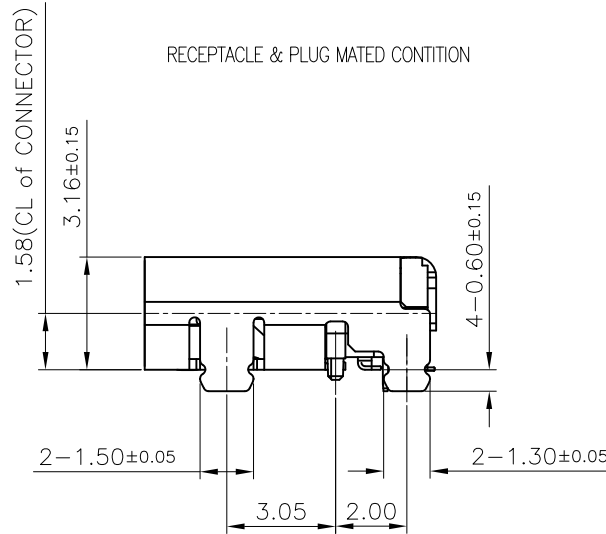
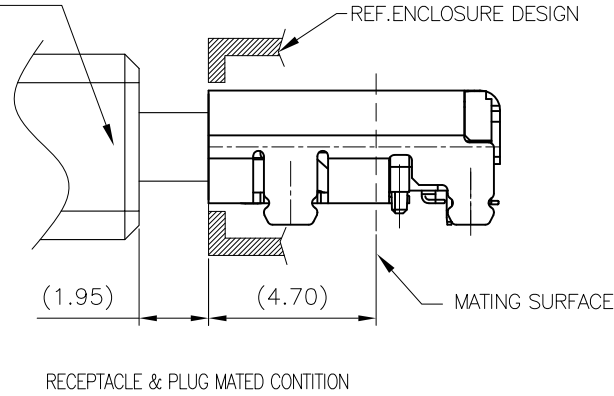

NOTES:

- MATERIAL:
 - HOUSING: THERMOPLASTIC, HIGH TEMP., UL94V-0;
 - CONTACT: HIGH CONDUCTIVITY COPPER ALLOY
 - GROUND PIN: STAINLESS STEEL
 - OUTER SHELL: STAINLESS STEEL
- FINISH:
 - CONTACT:
 - GOLD FLASH ON CONTACT FOR LEAD FREE.
 - 30u" Au ON CONTACT FOR LEAD FREE.
 - 80u" NICKEL UNDERPLATING OVERALL.
 - GROUND PLATE & SHELL:
 - 50u" MIN SOLDERABLE NICKEL UNDERPLATING OVERALL.
- SPEC. PLS. REFER TO PS-55907-xxxx-xxx
- PACKAGE PLS REFER TO 31862-xxxx-xx-TRP
- PART NUMBER

31862-024 X X-001

NO OF CKT _____

PACKING _____ PLATING _____

0: TAPE & REEL D: 30u" Au

2: GOLD FLASH

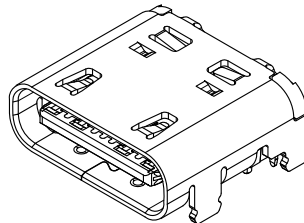
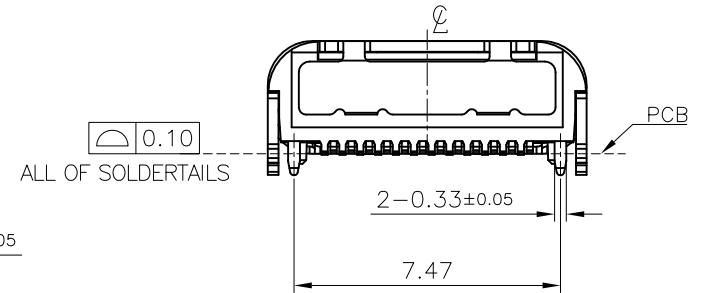

PIN NO.	A1	A2	A3	A4	A5	A6	A7	A8	A9	A10	A11	A12
SIGNAL NAME	GND	SSTxp1	SSTXn1	VBUS	CC1	Dp1	Dn1	SBU1	VBUS	SSRXn2	SSRXp2	GND
PIN NO.	B12	B11	B10	B9	B8	B7	B6	B5	B4	B3	B2	B1
SIGNAL NAME	GND	SSRXp1	SSRXn1	VBUS	SBU2	Dn2	Dp2	CC2	VBUS	SSTXn2	SSTXp2	GND

QUALITY SYMBOLS	DRAWN BY	DATE
MAJOR Ⓜ	Chang, Chun Wei	18/01/24
CRITICAL Ⓢ	CHECKED BY	DATE
GENERAL TOLERANCES (UNLESS SPECIFIED)	Chang, Chun Te	18/01/24
X. ±0.5	APPROVED BY	DATE
.X ±0.25	Kuo, Rong Hsun	18/01/24
.XX ±0.15	UNITS	mm
.XXX ±0.1	SCALE	2:1
ANGLES ±2°	SHEET NO.	1 OF 1

TITLE	
USB TYPE C REC CONN. DUAL SMT TYPE	
SIZE	DWG NO.
A4	31862-024XX-XXX
SCALE	PART NO.
2:1	SEE NOTES

4	OUTER SHELL	1	STAINLESS STEEL / Ni PLATED
3	GROUND PLATED	1	STAINLESS STEEL / Ni PLATED
2	CONTACT	24	COPPER ALLOY / Au PLATED
1	HOUSING	1	HI-TEMP. UL94V-0
ITEM	NAME	Q'TY	MATERIAL / FINISH

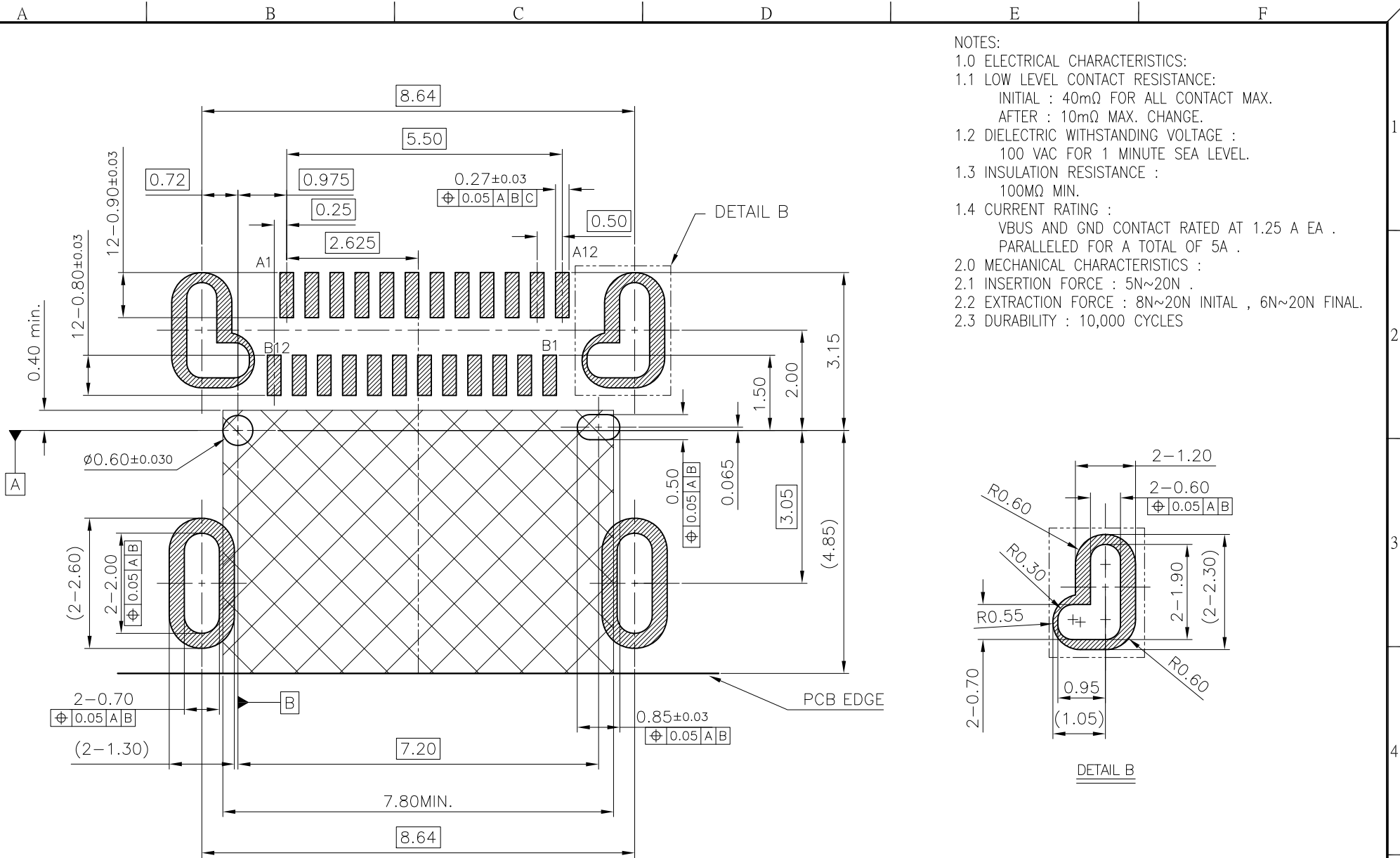

- NOTES:
- 1.0 ELECTRICAL CHARACTERISTICS:
 - 1.1 LOW LEVEL CONTACT RESISTANCE:
INITIAL : 40mΩ FOR ALL CONTACT MAX.
AFTER : 10mΩ MAX. CHANGE.
 - 1.2 DIELECTRIC WITHSTANDING VOLTAGE :
100 VAC FOR 1 MINUTE SEA LEVEL.
 - 1.3 INSULATION RESISTANCE :
100MΩ MIN.
 - 1.4 CURRENT RATING :
VBUS AND GND CONTACT RATED AT 1.25 A EA .
PARALLELED FOR A TOTAL OF 5A .
 - 2.0 MECHANICAL CHARACTERISTICS :
 - 2.1 INSERTION FORCE : 5N~20N .
 - 2.2 EXTRACTION FORCE : 8N~20N INITIAL , 6N~20N FINAL.
 - 2.3 DURABILITY : 10,000 CYCLES

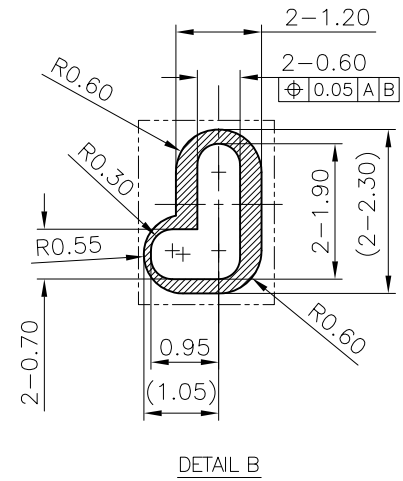

RECOMMENDED PCB LAYOUT

TOP VIEW
SCALE 10:1
(TOLERANCE = ±0.05mm)

QUALITY SYMBOLS MAJOR CRITICAL GENERAL TOLERANCES (UNLESS SPECIFIED) X. ±0.5 .X ±0.25 .XX ±0.15 .XXX ±0.1 ANGLES ±2°	DRAWN BY Chang, Chun Wei 18/01/24	DATE 18/01/24				
	CHECKED BY Chang, Chun Te 18/01/24	DATE 18/01/24			TITLE USB TYPE C REC CONN. DUAL SMT TYPE	
	APPROVED BY Kuo, Rong Hsun 18/01/24	DATE 18/01/24	UNITS mm		SIZE A4	DWG NO. 31862-024XX-XXX
	SCALE 2:1	SHEET NO. 1 OF 1	REV 0	PART NO. SEE NOTES		